

# Loading Mechanics of the 'Can' and Implications for Improved Strength and Stiffness Properties

G Tarrant<sup>1</sup>

## ABSTRACT

Improved roof control in high deformation tailgate environments has been achieved over the last decade through development of stiffer and increased capacity standing support products. 'The Can' is one such development, being a steel cylinder containing a weak cementitious fill, designed to essentially fold in upon itself whilst maintaining strength. A laboratory study to better define the relative load contributions of the steel cylinder and fill, the confining interaction between these components and most importantly, the potential impact of varying the steel and/or fill properties is described. This would enable the support engineer to 'dial-up' the desired strength and stiffness properties and optimise the standing support design with respect to load capacity, stiffness, weight (handling) and cost. Design curves to optimise strength based on steel casing thickness, fill strength (confined and unconfined) and 'Can' geometry were established. Scaled-down (one-third) samples were used in the test program and found to adequately reflect the loading behaviour of full-scale versions, thereby providing significantly greater scope for further product development at less expense compared with testing full-scale products.

## INTRODUCTION

A laboratory study of the interaction between the steel casing and fill material of 'The Can' standing support is described. Whilst the overall load/deformation characteristics of the product had previously been obtained by full-scale laboratory tests conducted by NIOSH (Pioneer Burrell, 1995), the relative contribution of the steel cylinder versus filler had not been established. This information was required for the development of stiffer and higher capacity (or softer and lower strength) systems. Unfortunately, the cost and logistics of conducting full-scale tests were prohibitive so the study was conducted using scaled-down (one-third) versions of the product.

The objectives of the testing program were:

- to measure the confinement provided by the steel casing to the filler and the consequential increase in strength of the fill material;
- to relate the scaled-down tests to full-scale versions and thereby establish the applicability of using scaled-down versions in product development;
- to establish design criteria regarding steel thickness, filler properties and 'Can' geometry; and
- to better understand the field loading behaviour of the product.

Three mini-cans were tested, one of which was tested as an empty steel cylinder. Each can was instrumented with 20 strain gauges to measure axial and circumferential strains. The study objectives were achieved, thereby providing the support design engineer with the ability to 'dial-up' the desired support properties of stiffness and strength within practical limitations such as weight and cost.

## BACKGROUND

### The product

'The Can' was developed by Burrell Mining for in the USA on a 'yieldable confined core concept' (UPSTO, 1994). It is composed of a cold rolled steel cylinder filled with a foamed cementitious

blend including flyash. The 'Can' is typically handled underground using an Eimco with claw attachment which currently constrains the weight of the product to approximately 2.0 t. Its use is widespread throughout the coal mining industry.

Generally if a higher capacity product is desired, then a larger diameter 'Can' is used. However handling limitations and other aspects such as the disruption to ventilation and access are also important issues that limit the strength achievable. A 915 mm diameter 'Can' is typically the largest used with a yield of approximately 160 t. In the absence of further testing, the opportunity for the mine engineer to optimise support cost against other variables such as support capacity, density, size or handling is limited.

Figure 1 illustrates characteristic load/deformation profiles of various standing support products, including the 'Link n Lock' and pumpable cement systems. The strength of the largest products in widespread use is limited to approximately 160 t for the high yield types. Greater capacity is achievable through the pumpable products however there is a rapid reduction in post yield strength for these types. It is emphasised that the purpose of this paper is not to discuss the benefits of one product over another since they all have application in differing environments.

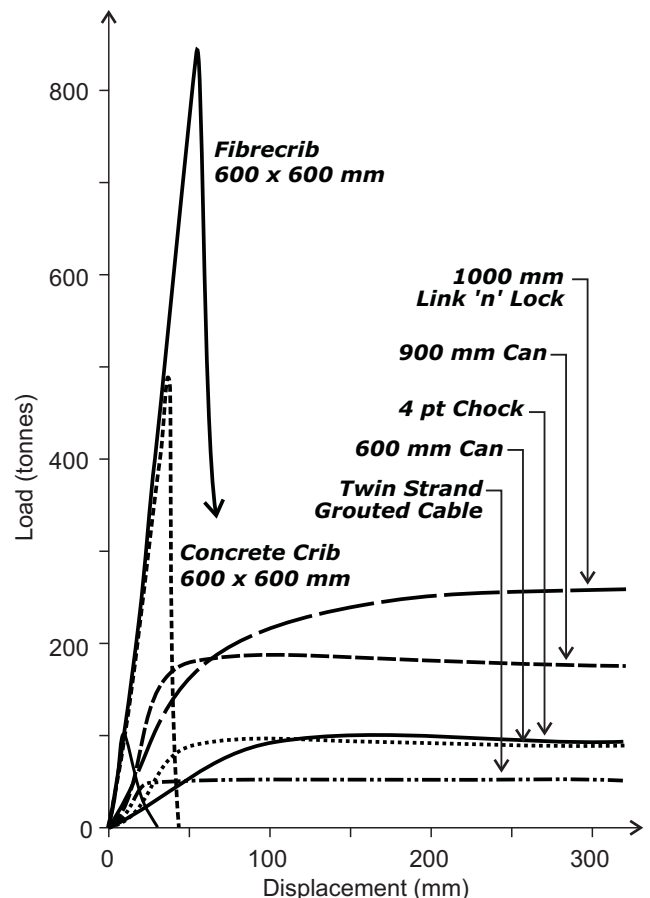

FIG 1 - Comparative load/displacement of selected standing supports (after Barczak, 2000).

1. MAusIMM, Senior Strata Control Engineer, SCT Operations Pty Ltd, PO Box 824, Wollongong NSW 2520. Email: gtarrant@sctaust.com

**Previous research**

Concrete filled steel tubes (CFTs) are used within civil construction due in part to the economic benefits of using concrete versus steel. Substantial research into this area has been conducted over the last 60 years (O’Shea and Bridge, 1994, 1997a, 1997b; O’Shea, 1998; Morino and Tsuda, 2002) with the initial focus on thick walled steel cylinders and normal strength concrete (15 to 50 MPa). The increased cost of steel has driven research towards thinner steel tubes and use of higher strength concretes (100 MPa). Aziz *et al* (2001) conducted a range of tests on 150 mm diameter, 500 mm high steel tubes (1 mm thick) filled with a variety of low strength fillers between 3.6 and 22.9 MPa. The work found that changes in filler strength influenced the bearing capacity of the composite columns. The body of existing research provided some insights into the behaviour of CFTs in general and particularly in relation to:

- the strength of the steel tube component,
- the possible load distribution between concrete and steel, and
- the ductility of the steel/concrete composite.

Essentially the concrete core interacts with the steel casing only after yield of the concrete occurs. The resistance provided by the steel casing may increase the post yield strength of the concrete depending on the relative strain characteristics of the concrete and steel.

The total load developed by a CFT can be separated into the contributions of the concrete, the bare steel tube and confining effects of the steel provided to the concrete. According to the research, the maximum contribution of the steel cylinder can be determined independently of the fill using existing buckling formulae (AS 4100, 1990; Grimault and Janss, 1977; AISC-LRFD, 1994). The presence of the fill doesn’t enhance the load at which buckling occurs since buckling is usually directed outward, not inwards. The contribution of the concrete can be separated into its unconfined and confined components.

The post yield behaviour of a CFT and its ultimate strength depend on whether or not the CFT exhibits strain hardening or softening characteristics. This is again a function of the radial strain characteristics of the concrete and the confining response of the steel casing.

**Composite strength of concrete filled steel tube**

Figure 2 illustrates the stress conditions in the steel tube and concrete core. From the equilibrium of forces a relationship between the hoop tensile stress  $\sigma_h$  and the internal pressure  $\sigma_r$  can be established (Equation 1).

$$\sigma_r = \frac{t}{r} \sigma_h \tag{1}$$

where:

r and t are the radius and thickness of the steel respectively

The strength of the confined concrete is given by the following relation:

$$\sigma_{1c} = UCS + TSF * \sigma_{3c} \tag{2}$$

where:

TSF is the triaxial stress factor given by  $(1+\sin\phi)/(1-\sin\phi)$

$\phi$  is the internal angle of friction

$\sigma_{1c}$  is the strength of the concrete

UCS is the unconfined compressive strength

$\sigma_{3c}$  is the lateral confining stress

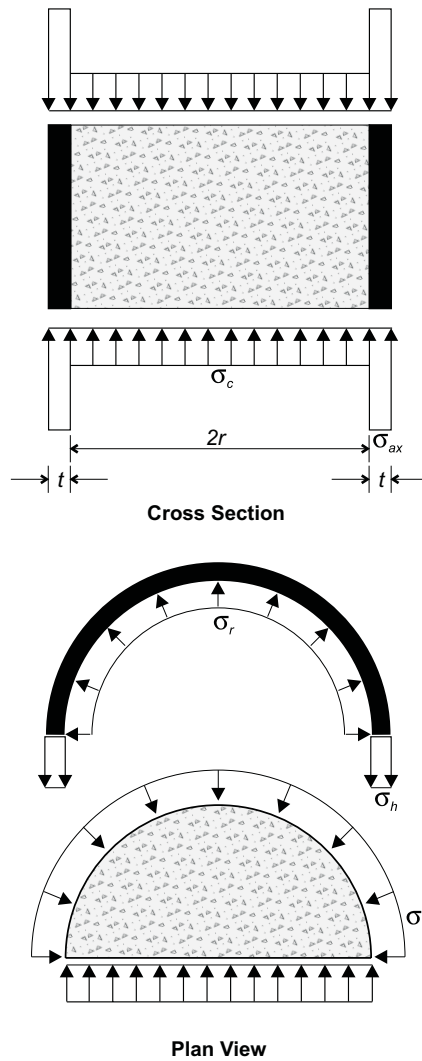

FIG 2 - Stress conditions in the steel tube and the concrete core (after Johansson and Akesson, 2001).

The form of this equation is well recognised within geomechanics in relation to rock strength.

Substitution of  $\sigma_r$  into Equation 2 gives the relationship between the hoop stress developed in the steel casing and the concrete strength.

$$\sigma_{1c} = UCS + TSF * \frac{t}{r} \sigma_h \tag{3}$$

The total load in the CFT can now be written in terms of the sum of the contributions from the concrete and steel according to Equation 4.

$$L_T = L_C + L_S = \left( UCS + TSF * \frac{t}{r} \sigma_h \right) A_C + \sigma_s A_s \tag{4}$$

where:

$A_C$  and  $A_S$  are the respective areas of the concrete column and steel (note that an effective area approach would be used for the load in the steel)

$L_T$  is the total load

$L_C$  is the load in the concrete

$L_S$  is the load in the steel

Equation 4 provides a relationship between the components of the composite system. The fill properties of UCS and TSF can be determined by triaxial testing in the laboratory and the load at yield of the steel cylinder can be estimated from empirical formulae or also determined through testing. The radial strain of the concrete and the consequential resisting confinement developed by the steel casing is obtained either empirically (as in this study) or numerically through use of FEM code.

### Implications for mini-can tests

The measurement of hoop stresses in 'Cans' has never been conducted and following a request for information from the manufacturer, the buckle strength of empty 'Cans' has also never been conducted. No published data exists for the triaxial properties of the fill typically used in the 'Can'. If development of the 'Can' was to include analytical evaluation (use of Equation 4) of different fill types, steel cylinder geometries or casing materials, the following aspects required either measurement or confirmation:

- The applicability of the empirical equations developed for bare steel tubes for the very high D/t ratios should be evaluated. The mining application of CFTs are characterised by very high D/t ratios (>450) compared with the civil application (D/t ratios typically <90).
- The triaxial strength properties of the fill required determination. The fill typically used in the mining application of CFTs is very weak (<3 MPa) compared with the civil application (15 to 100 MPa).
- The radial strain behaviour of the fill and the confining response of the steel tube required measurement.

The mini-can laboratory tests were designed to gain a better understanding of these aspects.

## TEST SERIES

### Test specimens

The mini-cans were manufactured by Pioneer Burrell without specific instruction regarding the welds or degree of roundness. Each mini-can was constructed with a single longitudinal weld and was capped at one end. In the vicinity of the longitudinal welds, local warping of the cans was visible. The dimensions and weight of the mini-cans are provided in Table 1. One of the filled

**TABLE 1**  
Steel material properties and 'Can' dimensions.

Specimen	Diameter (mm)	Thickness (mm)	Length (mm)	Weight (kg)
1	311.0	1.9	1006	13.4
2	311.0	1.9	992	65.8
3	311.9	1.9	993	76.2

**TABLE 2**  
Fill test results.

Sample	Sample diameter (mm)	Sample length (mm)	Moisture content (%)	Density (g/cc)	Confining stress (MPa)	UCS (MPa)	E (GPa)	Poisson's ratio
1	50.8	110.4	16.3	0.635	0	2.4	1.6	0.21
2	50.9	109.8	15.2	0.614	0	1.9	1.5	0.23
3 <sup>†</sup>	51.0	102.8	16.2	0.616	0.2	1.7 <sup>†</sup>	n/a	n/a
4 <sup>†</sup>	50.9	98.8	13.3	0.596	0.4	1.7 <sup>†</sup>	n/a	n/a
5 <sup>†</sup>	50.8	100.7	12.3	0.599	0.8	1.7 <sup>†</sup>	n/a	n/a

<sup>†</sup> Inferred from extrapolation of triaxial test series.

cans was 10 kg lighter, indicating the presence of a large air pocket within the specimen. Greater control over the filling procedure and checking of the weight at the time of specimen filling would be required for future tests. The filled specimens were noted to have some steel (<5 mm) proud of the fill due to uneven settlement. Due to the size and weight of the specimens, no attempt was made to machine the ends parallel. Instead the specimens were topped with normal cement and levelled.

Given the extent of the imperfections, the small scale tests should be considered a 'first pass' evaluation. Future use of small scale specimens would require much tighter tolerances and development of standard procedures to reduce the variables introduced into the testing process. The effect of imperfections would be expected to become more pronounced with further reductions in specimen size.

### Fill testing

Small fill samples of approximately 50 mm diameter × 100 mm length were poured to establish the unconfined compressive strength (UCS), Poisson's ratio, Young's modulus and triaxial strength characteristics. The tests were conducted by Strata Testing Services Pty Ltd according to Australian Standard AS 4133.4.3 (1993) and in the case of the triaxial tests, ISRM-suggested methods. The fill test results are summarised in Table 2. Figure 3 indicates that the strength increase versus confinement or triaxial stress factor (TSF) was approximately 1.9, which is considerably lower than the value of 4.1 typically used in the prediction of CFT strength (Morino and Tsuda, 2002) for example). The relatively low value of TSF indicates that the strength of the fill material is not enhanced to the same extent (50 per cent) as that of normal strength concrete.

### Test results

The tests were conducted at the University of Sydney, Civil Engineering laboratory using the Dartek 200 tonne capacity machine. All tests were concentric, axial loading conducted under stroke control at a rate of 5 mm/minute. The post yield characteristics of one of the tests (number 3) were investigated under stroke control of 25 mm/minute. Ten pairs of axial and circumferential linear strain gauges were attached to each can in the configuration shown in Figure 4. The strain gauges were logged automatically by a Datataker. The Appendix illustrates the typical strain gauge output from the tests.

### Bare steel tube

The load versus axial shortening of the bare steel tube is shown in Figure 5. An initial seating-in of the bare steel tube was evident from the initial portion of the stress/strain curve, occurring over approximately 2 mm. The maximum load was 270 kN and yield occurred due to local buckling as shown in Figure 6.

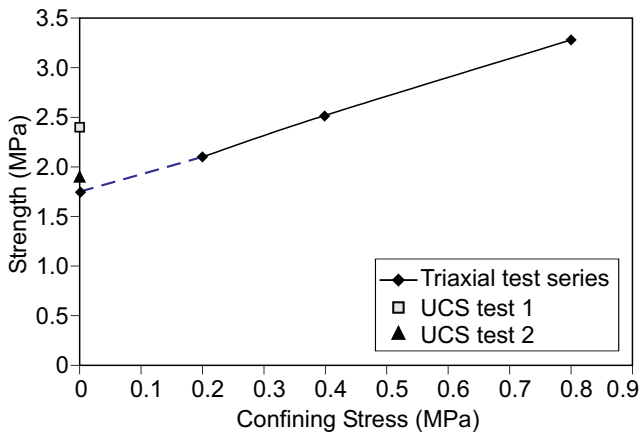

FIG 3 - Strength versus confining stress of the fill.

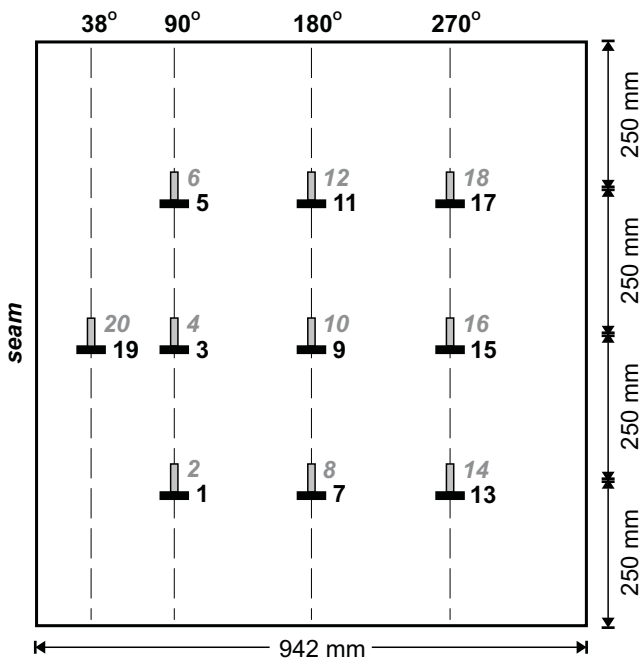

FIG 4 - Layout of the strain gauges relative to the longitudinal seam.

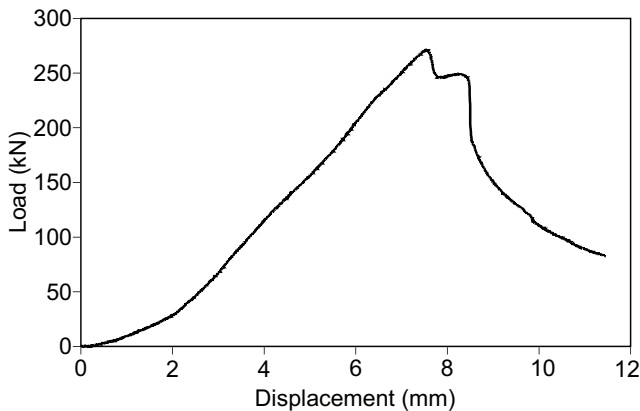

FIG 5 - Load versus displacement of empty can (sample 1).

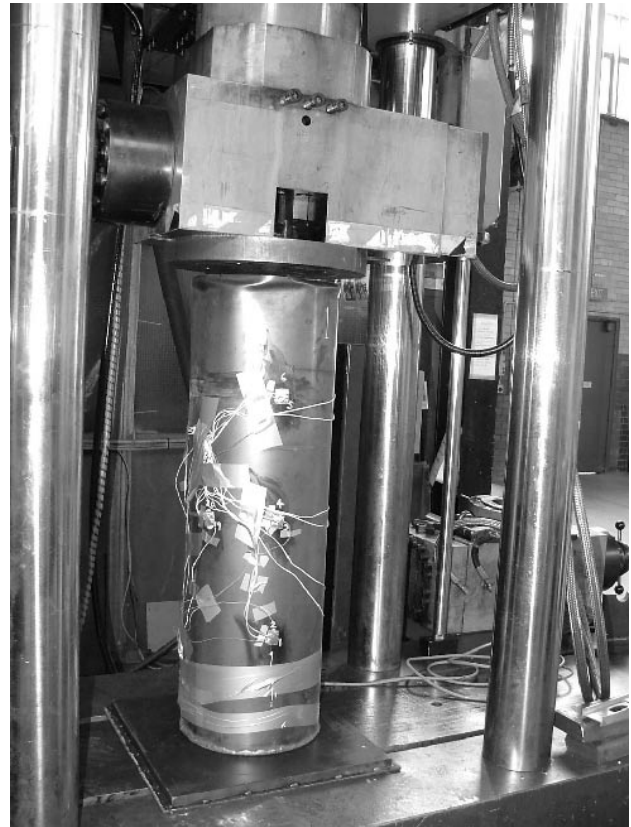

FIG 6 - Local buckling of empty can.

Various codes have been developed to predict the buckling loads of bare steel cylinders, including Australian Standard AS 4100 (1990), AISC-LRFD (1994) and Grimault and Janss (1977). Figure 7 illustrates the range in predicted strength for these codes for 1.9 mm thick steel tubes and Table 3 is a summary for the mini-can and larger versions typically used underground.

Clearly there is a variation in the predicted loads with the AISC-LRFD (1994) code predicting significantly higher tube loads at larger diameters. This may reflect the level of conservatism applied by the respective standards committees as well as the range of cylinder geometries forming the empirical basis of the codes. O'Shea and Bridge (1997a) note that AISC-LRFD (1994) give accurate predictions except for the thinnest tubes and were also developed for cold formed steels. If it is assumed that the LRFD code would be inappropriate for this study, the remaining AS 4100 (1990) and Grimault and Janss (1977) codes provide a guide to the expected strength of the bare steel tubes. Further investigations would benefit from measurement of the bare steel tube strengths for the larger scale 'Cans'.

The discrepancy between the tested peak load and the predicted peak load from the codes is partially attributed to the conservatism embodied in the code guidelines and partially due to the imperfections in the test specimen, particularly the uneven initial loading due to the out of squareness between the top and base of the tube. The use of smaller steel tubes would allow better tolerances for sample preparation since machining of the ends within a standard lathe would be possible.

**Filled mini-cans**

The load versus axial strain of the filled cylinders is provided in Figure 8, which also shows the bare tube test for comparison. The load at yield of the mini-cans was 46 and 48 t for samples 2 and 3 respectively. Both mini-cans yielded due to local buckling

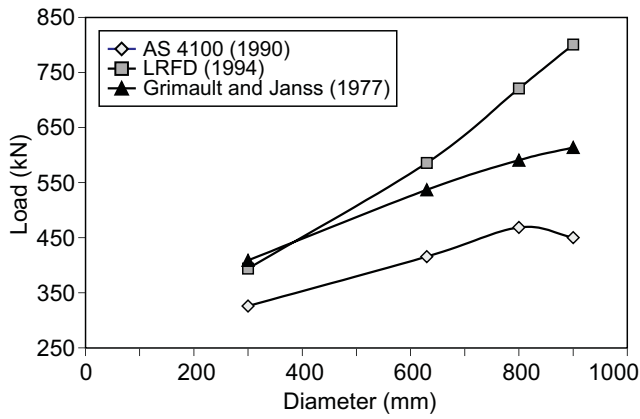

FIG 7 - Tested bare steel tube strength compared with predicted strengths from various codes.

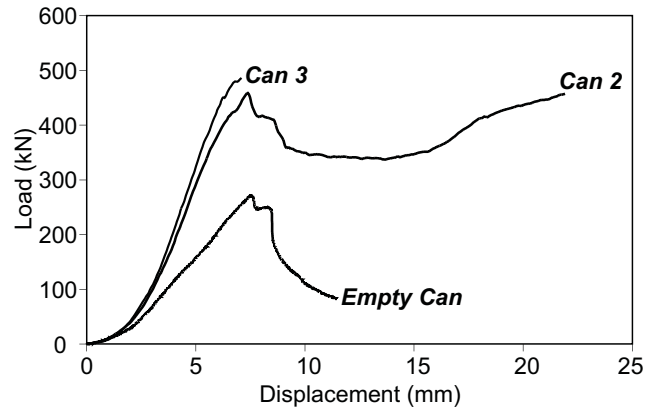

FIG 8 - Load versus displacement for the empty and filled mini-cans (300 mm diameter).

**TABLE 3**

*Tested versus predicted load of bare steel tube.*

Diameter	Test load (kN)	AS 4100 (1990)	AISC-LRFD (1994)	Grimault and Janss (1977)
300	270	326	394	409
630	Not tested	415	585	537
800	Not tested	468	721	590
900	Not tested	450	800	614

at the top of the cylinder as shown in Figure 9. The similar yield load for both mini-cans was somewhat surprising given that specimen 2 was 10 kg lighter than specimen 3. This aspect is elaborated further in the discussion section.

The post yield behaviour of specimen 3 was examined in greater detail. The stroke rate was increased to 25 mm/minute and continued until the stroke limit of the testing machine (225 mm). Figure 9 illustrates the development of local buckles

at various positions along the can. The mini-can was noted to develop a single outward buckle at the top of the can at yield, then followed by a further buckle approximately 50 mm below the first. The mini-can proceeded to concertina until both buckles made contact.

The load versus displacement plot including post yield is illustrated in Figure 10. The peaks and troughs of the load history were noted to coincide with the concertina process of buckle development followed by closure as buckles made contact with other buckles. The load difference between peaks and troughs was approximately 10 t or 20 per cent of the load at yield. Each trough and peak load was successively higher than the previous, indicating a strain hardening behaviour.

Figure 11 illustrates the axial versus circumferential strain for gauges nine and ten, Can number 3 (refer Figure 4). The plot clearly indicates that at the onset of buckling at the top of the mini-can, partial elastic unloading of the steel occurred in both the axial and circumferential directions. Since the steel is behaving plastically only locally, once the vertical displacement has increased by a buckle wavelength, elastic reloading of the steel tube can occur.



a) Initial buckling.



b) Continued buckling.



c) Continued buckling Can #3, 22% axial shortening.

FIG 9 - Development of local buckling Can #3.

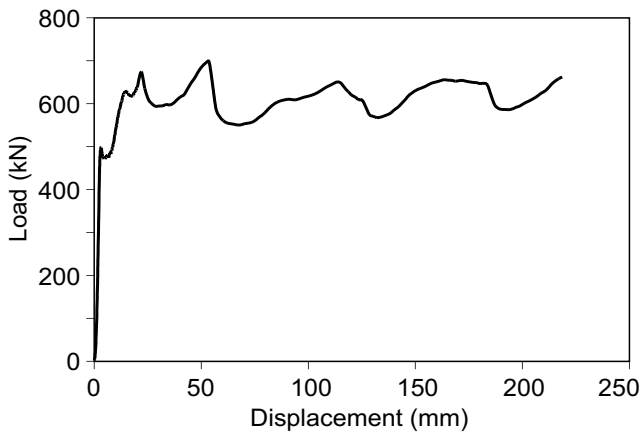

FIG 10 - Load versus displacement Can #3 (25 mm/min strain rate).

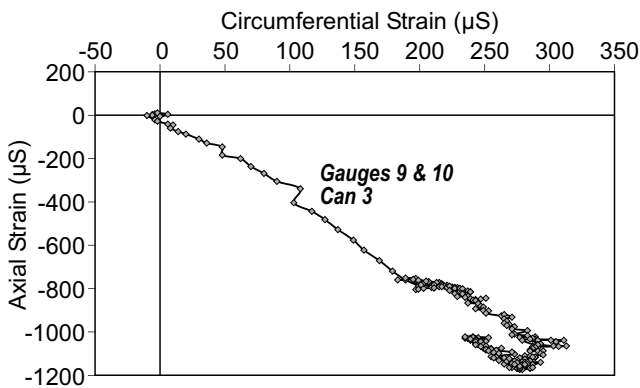

FIG 11 - Axial versus circumferential strain at midpoint – Can #3.

### Confinement generation

The confining stress provided to the fill by the steel casing was calculated from the averaged circumferential strains and the steel properties. An average circumferential strain of  $60 \mu\text{s}$  was attributed to the interaction between the fill and the steel cylinder.

The total circumferential strain in the steel cylinder is the sum of the circumferential strain associated with axial loading (Poisson effect) and the circumferential strain due to expansion of the fill:

$$\epsilon_{CT} = \epsilon_{c,ax} + \epsilon_{c,exp} \quad (5)$$

where:

$\epsilon_{CT}$  is the total circumferential strain

$\epsilon_{c,ax}$  is the circumferential strain due to axial loading of the cylinder

$\epsilon_{c,exp}$  is the circumferential strain due to the concrete expansion

and since:

$$\epsilon_{c,ax} = -\nu\epsilon_{ax} \quad (6)$$

where:

$\nu$  is the Poisson's ratio of the steel

$\epsilon_{ax}$  is the axial strain in the steel

The incremental confining pressure provided to the fill after Equation 1 and recast in terms of circumferential strain is given by:

$$\Delta p = \Delta \epsilon_{c,exp} E_s \left( \frac{t}{r} \right) \quad (7)$$

The total confining pressure provided by the steel casing to the fill at yield was calculated to fall within the range 0.15 to 0.2 MPa. The confining stresses enhanced the mini-can strength by only 20 kN out of a load at yield of 480 kN.

## DISCUSSION

### Deformation style

The deformation of the mini-cans was consistent with that observed underground for full-scale products, in particular the key feature of local buckle development and concertina behaviour of the steel tube. The behaviour of the mini-can was also consistent with experimental test work conducted by research into the application of concrete filled tubes (CFTs) to the civil industry. The civil research indicated that the shape of the steel section has a significant effect on the development of local buckles with circular sections generally buckling outward and square or rectangular section buckling both inward and outward. The yield strength of sections that buckle outward would not be expected to benefit from the presence of fill.

The mini-cans tests provided further insight into the post yield behaviour of the steel section. Whereas a bare steel tube will continue to deform until losing all strength, the presence of the fill results in the controlled concertina effect. In the early stages of yielding, a single buckle forms. With progressive axial displacement equal to the buckle wavelength, the steel cylinder has effectively regained its original shape and the load increases until another buckle commences. The cycle results in an oscillation of the peak load as deformation progresses.

### Comparison with full-scale tests

Figure 12 illustrates the peak load achieved in the filled mini-can tests compared with the published data available for 630, 800 and 900 mm 'Cans' (Pioneer Burrell, 1995) and predictions of the peak load using Equation 4 based on:

- bare steel tube strength,
- unconfined fill strength, and
- confined fill strength based on measured hoop stress.

The results are summarised in Table 4. The range of predicted loads shown in Figure 12 was established using both the AS 4100 (1990) and Grimault and Janss (1977) codes for predicted strengths for bare steel tubes. The predicted 'Can' strengths using these two codes (for the bare steel tube strength component) were found to bracket the measured loads based on these codes.

Figure 13 is a bar graph of the relative load contributions of the steel cylinder, unconfined fill and confined fill. The basis of the graph is the predicted strength of the steel cylinders assuming AS 4100 (1990) code for bare steel tubes, the measured UCS of the fill (1.7 MPa) and the predicted confining stresses extrapolated from the mini-can tests to the larger diameter 'Cans'. The plot is presented as cumulative to more easily identify the contribution of the confinement generated. The estimated confining stress generated for a 915 mm 'Can' was approximately 0.05 MPa (increasing the fill carrying capacity by 60 kN).

**TABLE 4**  
Actual versus predicted peak 'Can' loads.

Diameter (mm)	Predicted (AS 4100)	Predicted (Grimault and Janss) (kN)	Tested (kN)
300	467	550	550
630	989	1010	1016
800	1378	1500	1360
900	1593	1757	1645

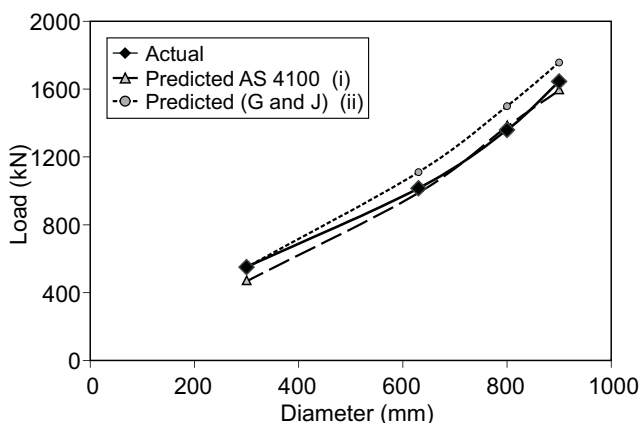

**NOTES:** (i) lower bound assuming AS 4100 (1990) code for steel tube  
(ii) upper bound assuming Grimault and Janss (1977) code for steel tube

FIG 12 - Total load versus diameter – predicted versus actual.

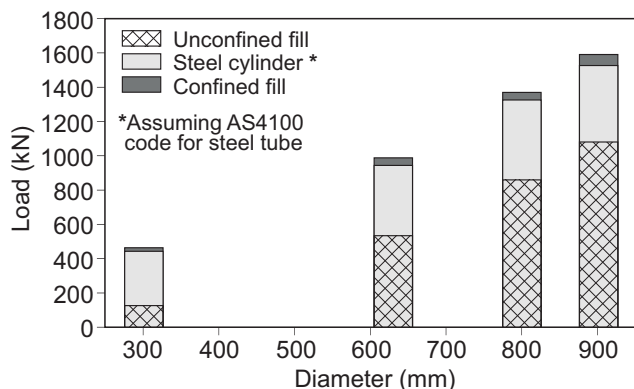

FIG 13 - Relative load distribution of the steel cylinder, unconfined and confined fill.

Inspection of Figure 13 indicates that as a first pass approximation, the 'Can' loads could be predicted to within a reasonable level of accuracy if the effect of confining stresses was simply ignored. The 'Can' strength could be predicted reasonably well by simply adding the bare steel tube strength to the unconfined fill strength. The contribution of the confining stress generated to the overall strength of a 915 mm diameter can represents approximately four per cent of the total load. The low magnitude of confining stress generated ( $<0.2$  MPa in the mini-can) was indicative that beyond yield, the volume of the fill continued to decrease rather than exhibit dilation. The fill behaviour was one of collapse of the skeletal fabric and reduction in void space (local crushing) rather than generation of shear failure surfaces with consequential dilation effects.

## Implications for product development of the 'Can'

Based on the results obtained, the role of the steel tube is to principally develop axial load and to physically restrict the movement of the fill so as not to allow sloughing however minimal enhancement of the fill strength is provided by the steel. The steel tube accounts for approximately 35 per cent of the total load in a 900 mm diameter 'Can'.

### Cuttability

A cuttable and presumably softer material would be expected to generate less confining stress to the fill compared with steel. However given the low contribution of the confined fill (four per cent) the consequential reduction in strength from loss of this confinement would be minimal. Since the steel tube provides approximately 35 per cent of the total load for a 915 mm 'Can', an equivalent strength of non-steel material would be required to maintain the same load capacity. Since the steel contribution increases to nearly 50 per cent for a 600 mm 'Can', the requirement for the non-steel material to provide an equivalent load capability compared with the steel increases. In other words, the penalty in peak load terms for a 600 mm cuttable 'Can' is more severe compared with a 900 mm cuttable 'Can'.

### Steel thickness

Figure 14 is a plot of predicted 'Can' strength versus steel thickness for 600 mm and 915 mm diameter 'Cans' assuming:

- the same fill properties as that used currently,
- same steel strength properties, and
- buckle load based on AS 4100 (1990).

A linear increase in strength of approximately 45 or 50 t would be expected for every 1 mm increase in steel thickness for 600 mm and 900 mm diameter 'Cans' respectively. In relative terms, the impact of increasing steel thickness is greater for 600 mm versus 900 mm 'Cans'. This is a consequence of the greater relative contribution of the steel cylinder to the total load for smaller diameter 'Cans'. According to Figure 14, a steel thickness of 2.5 mm for a 600 mm 'Can' would achieve approximately the same strength as that for a 1.9 mm casing for a 915 mm 'Can'. As a precautionary note, the possibility of column buckling and the impact of lateral displacements should be considered in a field application of this finding.

### Fill strength

Figure 15 illustrates the expected increase in (915 mm) 'Can' strength for an incremental increase in fill UCS for various steel thicknesses. For every 1 MPa increase in fill UCS, the 'Can' capacity would be expected to increase by approximately 70 t, irrespective of the steel thickness. Increasing the fill strength by approximately 1MPa would therefore be expected to have a resulting increase in total 'Can' strength similar to that indicated by increasing the steel thickness by 0.5 mm. The practical drawback to increasing fill strength is the consequential increase in fill density which may increase the total 'Can' weight to an unacceptable level for handling underground.

### Confined fill properties

The contribution of the confined fill to the total 'Can' strength is influenced by both:

- the confining stress generated through interaction with the steel; and
- the responsiveness of the fill to that confinement (triaxial stress factor (TSF)).

Both of these characteristics are associated with the fill properties. From Equation 2, the increase in strength for a given confinement is related to the internal angle of friction of the fill. A

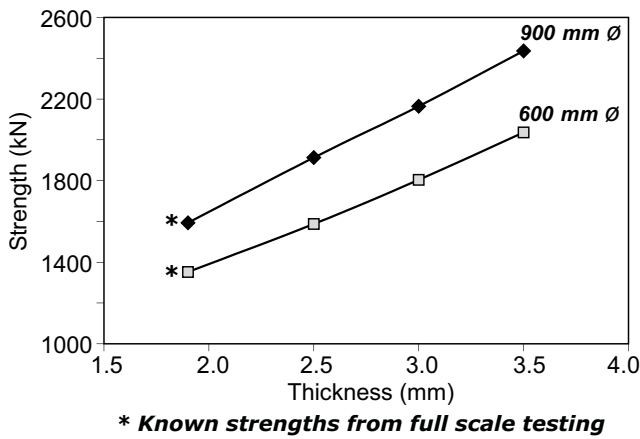

FIG 14 - Predicted affect of steel thickness on strength of 900 mm can.

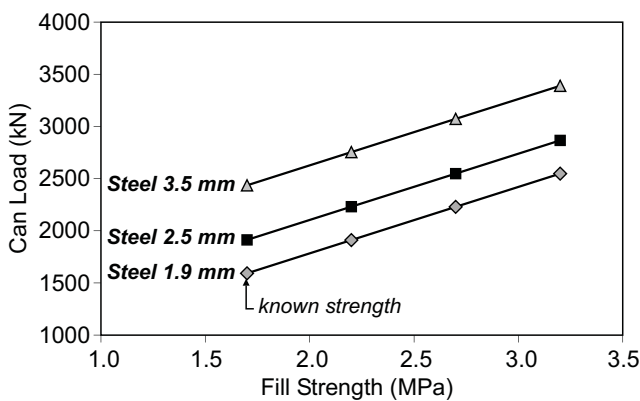

FIG 15 - Predicted affect of fill strength and steel thickness on strength of 900 mm can.

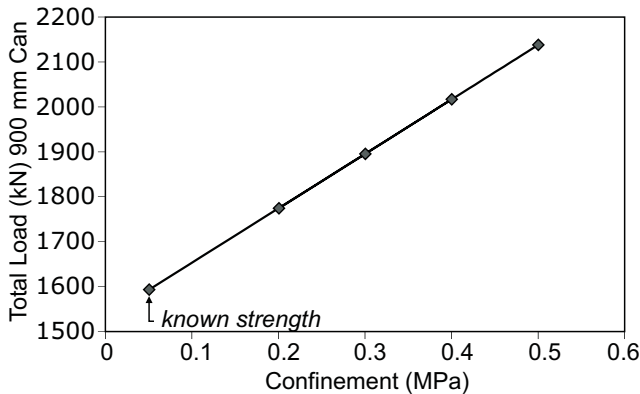

FIG 16 - Predicted affect of increased confining stress on strength of a 900 mm can.

value of 18° has been measured for the fill giving a triaxial stress factor of 1.9. The strength of the fill increases by 1.9 MPa for every 1 MPa of confinement provided by the casing. Based on the mini-can tests, the larger diameter 'Cans', generate a confining stress of only 0.05 MPa, increasing the fill strength by only 0.095 MPa (6 t for a 915 mm diameter). Figure 16 illustrates the expected increase in overall strength of a 900 mm diameter 'Can' for incremental increases in the confining stress generated between the fill and steel interaction, all other things being equal.

Recommendations to increase the internal angle of friction of the fill are beyond the scope of these investigations. In general terms the internal friction angle would be expected to increase through means such as increasing the level of interlocking between particles. This may include the relative proportions of the constituent mix, mechanical properties of the constituents, void ratio, etc.

The existing fill is like a foam with a skeletal fabric and large void ratio. The deformation of the fill is characterised by a progressive collapse of the skeletal fabric. Eventually the void ratio would be expected to decrease to the extent that the fill behaved more like an aggregate where volume increase would be expected to accompany continued deformation. Figure 9 illustrates that even after axial shortening of 22 per cent, the volume continued to decrease with increasing axial shortening (no barrelling of the cylinder evident). It is suggested that decreasing the void ratio would be expected to have the greatest impact on the level of confining stress generated by the steel and also the responsiveness of the fill to that confinement (internal friction angle). Increasing the steel thickness or limiting barrelling of the 'Can' by application of ring stiffeners or other means is unlikely to result in a significant increase in the confined strength of the existing fill.

### Casing strength

In civil applications where the concrete is intended to carry the bulk of the load and the role of the steel casing is to provide confinement, disconnection between the steel and the loading system (load concrete only) has been found to be desirable under some circumstances. In the mining application, the steel cylinder was found to form a significant contribution (>30 per cent) to the total system load, even after buckling. Future product development that may result in disconnection of the steel cylinder from the roof and floor or features that reduce the load at which buckling occurs should be avoided. The introduction of longitudinal ribs or other methods to delay the onset of local buckling would be expected to increase the strength of the steel cylinder and therefore the overall system strength.

The key point is that the role of the steel cylinder in the mining application is different to the civil application. In the mining application the role of the steel cylinder is to contribute to overall strength whereas the civil application the role is more one of confinement.

### Implications for field behaviour of the 'Can'

#### Stiffness

The axial shortening of the mini-can at yield was approximately 7500 µs or 7.5 mm for the 1000 mm test specimens both filled and unfilled. If this result is extrapolated to an underground application for a 'Can' length of 3 m for example, then yield would be expected at a minimum roof to floor convergence of 22.5 mm. This value does not include seating-in of packing materials or closure of gaps between the roof and support. The displacement at which yield occurs is also independent of 'Can' diameter assuming that column buckling does not occur. The value of 22.5 mm would also provide a useful indicator for the required expansion of a hydraulic packer or other device if pre-stressing of the 'Can' were considered as a design option.

The identical value of axial shortening to reach yield for an unfilled versus filled 'Can' indicates that yield of the composite is controlled by yield of the steel, not the fill. This is opposite to the civil application where higher strength concrete typically results in yield of the steel cylinder first. In the underground application, the observation of a local buckle would signify yield of the system (approximately 160 t for a 915 mm diameter 'Can'). No visible sign of system load would be provided by the



steel cylinder prior to yield. Loading could only be implied through compaction of the packing materials.

Whilst the 'Can' exhibits limited strain hardening (gains strength with convergence), the presence of local buckling would signify that additional resistance against further roof to floor convergence would be minimal. In many respects the ability to 'follow the roof down' and at least maintain load is a deliberate design aspect of the 'Can' and of standing supports in general. Improvement of the strain hardening characteristics of the product would be expected to have a positive impact on roof control in high deformation areas.

### Strength

The mini-can test program has highlighted the greater contribution of the fill (>60 per cent for 915 mm diameter versions) versus the steel to the overall strength of the 'Can'. Since the fill is considered to be a very weak material (UCS 1.7 MPa) and has very low responsiveness to confinement, development of improved fill strength both pre and post yield appears to be the best avenue for product improvement. The most significant implication of this aspect to the underground application is the increased weight which is limited by existing 'Can' carrying equipment (this assumes that the option of pumping grout into empty cans would violate the patent (Healy, pers comm)).

Since the strength of cementitious products generally increase exponentially with density, a small increase in overall weight may offer substantial increases in overall product strength. In addition to the increase in UCS, the responsiveness of the fill to confinement would also be expected to increase with a denser fill. Consideration of suitable equipment and OH&S issues associated with heavier 'Cans' is beyond the scope of this study however communications with colliery personnel suggest that increased weight of up to 100 per cent is feasible with existing handling equipment.

### Field load determination

Since the stiffness of the 'Can' is known and since the strain to yield is known (7500  $\mu$ s), estimation of the load could be obtained through measurement of the total top to base convergence. Given the value of 22.5 mm for a 3.0 m long can, this magnitude of displacement is measurable with a standard (and cheap) convergence pole. Note that the total roof to floor convergence would not provide a suitable 'strain' measurement because this value would include the deformation of the packing and closure of gaps between the support and the roof. The reference anchors would need to be attached to the 'Can' itself. The strain could also be measured with a simple measurement of the distance between two pins attached to the steel casing.

Once local buckling has occurred, the 'Can' exhibits strain hardening behaviour meaning that the load continues to increase with progressive roof to floor convergence. The measurement of load once local buckling has occurred could only be achieved through use of a load cell since the load/strain relationship becomes non-linear.

### Relevance of mini-can tests

The mini-can tests were able to provide a greater insight into the general mechanisms of load development in the 'Can', the findings of which have application to support design using existing products and application to product development. Most importantly, the measurement of the confining stress provided by the steel to the fill was found to be very low (<0.05 MPa for 900 mm diameter cans). The role of the steel cylinder is to carry load rather than provide confinement in the current configuration.

The strength of full-scale products were predicted from the results of the mini-can tests and found to agree well with full-scale testing already conducted. The ability to predict the behaviour and strength of larger scale versions from scaled-down tests indicates that small scale testing would be a suitable tool for product development. The ability to conduct cheaper and easier small scale tests would be expected to accelerate product development and ultimately provide the mining industry with improved support design and product choice.

The most important application of the scaled-down tests is the ability to conduct product development in the laboratory as a first pass, rather than the more hazardous alternative of trial and error in an underground situation.

### Improvements for future scaled-down testing

The preparation of the mini-cans was conducted according to tolerances applicable to the mining application. Unfortunately the presence of imperfections in the steel cylinders and lack of pre-testing conditioning resulted in an undesirable level of scatter in the strain gauge readings. The size and weight of the mini-cans (>60 kg) made proper sample preparation difficult. The results of the testing program indicate that with appropriate sample preparation, smaller scale cylinders would be suitable. Smaller samples would also make available a greater range of testing equipment (50 t capacity).

Investigations into improved fill properties could occur independently of the steel cylinder. Similarly, improved steel (or non-steel) cylinder strength could occur independently of the fill.

## CONCLUSIONS AND RECOMMENDATIONS

Testing of scaled-down versions of the 'Can' provided a suitable method to predict the stiffness and strength characteristics of full-scale versions in the field. The scaling parameters were a function of:

- strength of the bare (unfilled) steel tube at the onset of local buckling,
- strength of the unconfined fill, and
- contribution of confinement provided by the steel to the fill.

The various load contributions of the steel cylinder, unconfined fill and confined fill were determined for a range of 'Can' sizes. The unconfined fill and steel cylinder account for 63 per cent and 35 per cent of the total load respectively for a 915 mm diameter 'Can'.

The confining stress provided by the steel cylinder to the fill was found to be surprisingly low. The inferred confining stress developed in a 915 mm diameter 'Can' was approximately 0.05 MPa, which would account for only two per cent of the total load contribution.

Limited parametric analyses were provided to determine the relative impact of changes to the thickness of the steel cylinder and/or the fill strength. The properties of the fill, in particular the increase in strength with confinement were considered to be areas where significant improvements to overall 'Can' strength and stiffness could be achieved. These improvements would need to be assessed against the increased weight and associated handling issues.

Estimation of load in the 'Can' in the field could be obtained with reasonable accuracy by measurement of the axial strain at any point up to the onset of local buckling. The measured distance between two pins with a tape measure for example would be suitable.

The scaled-down tests would be a suitable 'first pass' to assess the field behaviour of non-steel 'Cans'.

The equations developed by the civil industry to estimate the buckle strength of thin walled steel tubes were developed empirically using D/t ratios significantly smaller than that

studied here. The AS 4100 (1990) and Grimault and Janss (1977) codes were considered suitable, however further empirical work should be conducted to fine tune the equations used.

**ACKNOWLEDGEMENTS**

The work presented was conducted under the auspices of ACARP as part of Project C12006 Tailgate Support – It’s Time for an Engineered Solution. Contributions to the C12006 Project were also made by:

- North Goonyella Coal Pty Ltd,
- Anglo Coal (Moranbah North Management) Pty Ltd,
- Metropolitan Collieries,
- BHP Billiton Illawarra Coal,
- Pioneer Burrell Mining Services (now Burrell Hansen),
- Strata Products,
- Ground Consolidation,
- Coalroc Contractors Pty Ltd, and
- SCT Operations Pty Ltd.

The funding provided by these companies is gratefully received. Pioneer Burrell is kindly thanked for the manufacture of the ‘mini-cans’.

In future tests of this nature, particularly at further reduced tube diameters, stricter control over the residual stresses induced by the manufacturing process should be used. No attempt was made in this program to measure the effects of the imperfections.

In future tests the mini-cans should not be capped since the capping affects the lateral restraint and therefore has an impact on the measurement of confining stresses provided to the fill.

**REFERENCES**

AISC-LRFD, 1994. *Metric Load and Resistance Factor Design Specification for Structural Steel Buildings*, First Edition (American Institute of Steel Construction).

AS 4100, 1990. *Steel structures*, Standards Australia, Sydney.

AS 4133.4.3, 1993. *Methods of Testing Rocks for Engineering Purposes – Rock Strength Tests*, p 7.

Attard, M M and Setung, S, 1996. Stress strain relationship of confined and unconfined concrete, *ACI Materials Journal*, Sept-Oct(93-M49):432-442.

Aziz, N I, Schmisdt, L C and Bhagwat, K D, 2001. Concrete filled thin walled cylindrical steel columns in mining applications, in *Proceedings Second International Conference on Mechanics of Structures, Materials and Systems*, pp 37-42 (University of Wollongong: Wollongong).

Barczak, T M, 2000. Optimizing secondary roof support with the NIOSH support technology optimization program (STOP), in *Proceedings 19th Conference on Ground Control in Mining*, Morgantown, WV (eds: S S Peng and C Mark) pp 74-83.

Bridge, R Q and Webb, J, 1992. Thin walled circular filled steel tubular columns, in *Proceedings Composite Construction in Steel and Concrete*, ASCE, pp 634-649 (Engineering Foundation: Potosi).

Grimault, J P and Janss, J, 1977. Reduction of the bearing capacity of concrete filled hollow sections due to local buckling, *Preliminary Report ECCS Colloquium on Stability of Steel Structures*, pp 175-179 (Liege).

Johansson, M and Akesson, M, 2001. Finite element study of concrete filled steel tubes using a new confinement sensitive concrete compression model, *Nordic Concrete Research*, No 27, 2/2001, pp 43-62 (Norsk Betongforening).

Morino, S and Tsuda, K, 2002. Design and construction of concrete-filled steel tube column system in Japan, *Earthquake Engineering and Engineering Seismology*, 1(1):51-74.

New Kensington, P A, Prion, H G L and Boehme, J, 1989. Beam-column behaviour of steel tubes filled with high strength concrete, in *Proceedings Code Differences Around the World, SSRC, Fourth International Colloquium North American Session*, pp 439-450.

Orito, Y, Sato, T, Tanaka, N and Watanabe, Y, 1987. Study on the unbonded steel tube concrete structures, in *Proceedings Engineering Foundation Conference on Composite Constructions*, Henniker, New Hampshire, USA, June, 16 p.

O’Shea, M D, 1998. PhD thesis, University of Sydney.

O’Shea, M D and Bridge, R Q, 1994. The design of circular concrete filled steel tubes, in *Proceedings Australasian Structural Engineering Conference*, pp 607-612 (The Institution of Engineers: Australia).

O’Shea, M D and Bridge, R Q, 1997a. Local buckling of thin-walled circular steel sections with or without internal restraint, Research Report R740, The University of Sydney, Department of Civil Engineering.

O’Shea, M D and Bridge, R Q, 1997b. Tests on circular thin-walled steel tubes filled with medium and high strength concrete, Research Report R735, The University of Sydney, Department of Civil Engineering.

Pioneer Burrell, 1995. A breakthrough system for longwall cribbing: The can cribbing system, Product brochures, Burrell Mining Products International Inc.

Schneider, S P, 1998. Axially loaded concrete filled steel tubes, *Journal of Structural Engineering*, 124(10):1125-1138.

Tomii, M Y, Yoshimura, K and Morishita, Y, 1977. Experimental studies on concrete filled steel tubular columns under concentric loading, in *Proceedings Int Colloquium on Stability of Structures Under Static and Dynamic Loads*, pp 718-741.

UPSTO, 1994. UPSTO patent full text and image database, Patent number 5 308 196 [online]. Available from: <http://www.upsto.gov>.

**APPENDIX  
INDIVIDUAL STRAIN READINGS**

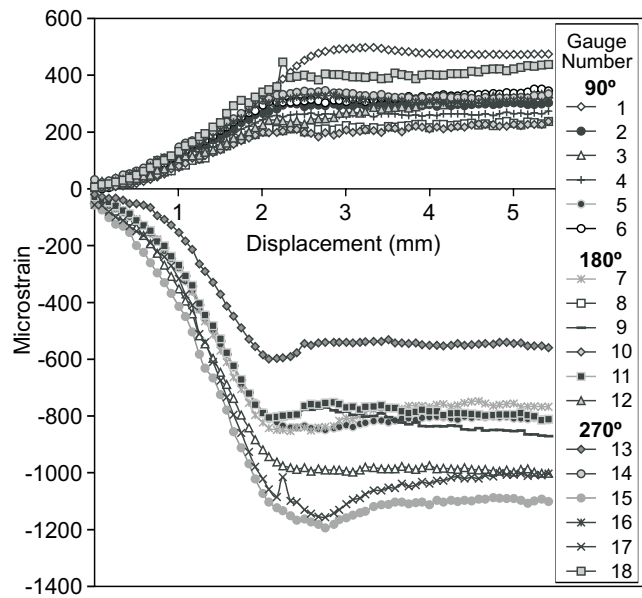

FIG A1 - Axial and circumferential strain – Can #3.